

Output Plug and Polarity are Dependent on Customer Requirements

General Specifications

- Input: 100~240Vac/ 47~63Hz
- Output: +48VDC/0~3300mA Regulated
- DC Cord: 3.9 FT, 16 AWG
- Operating/Storage Temperature: 0°C ~+40°C/ -20°C~+80°C
- Operating/Storage Humidity: 20%~80%RH/ 10%~90%RH
- Approvals: UL/CUL/FCC/BSMI/TUV/CCC/CHINA ROHS/CE/WEEE/ROHS/VI
- Meets Energy Efficiency Level VI Standards/ ErP Stage 2
- Protection: Over Voltage/Short Circuit/Over Current/Over Temperature
- Packaged Unit Weight: 1.54 lbs
- Carton Quantity: 12 pcs

White Inner Box Dimensions:

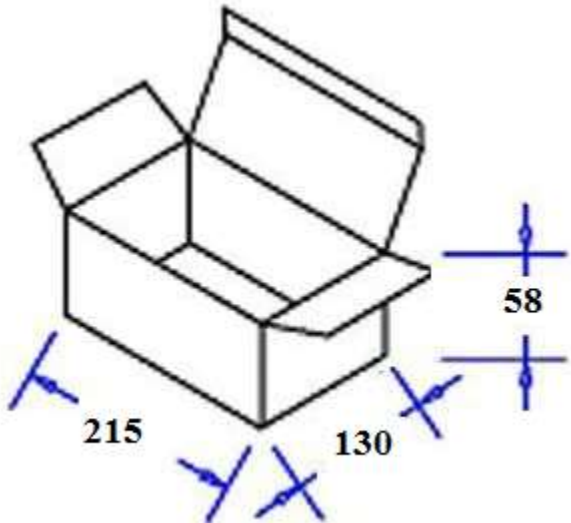

ITEM NO.	S-48V0-3A3-IDG30	PART TITLE	Energy Efficient 48 VDC / 3.3A Universal Input Power Supply
PART NO.	S6-483A3I	 CONDOR ELECTRONICS, INC. T: 408-745-7141 F: 408-745-0439 990 San Antonio Road Palo Alto, CA 94303 USA sales@condorelectronics.net	
DATE	1.28.2016		
APPROVAL	CB		
UNIT	mm		
REV	0		

160W Level VI – Desktop Series

Catalog Page

OnLine Part Number	Condor P/N	OUTPUT VOLTAGE	OUTPUT CURRENT	INPUT VOLTAGE	FREQUENCY
S-12V0-12A5-IDG30	S6-1212A5IV	12.0V	12.5A	100-240VAC	50-60Hz
S-19V0-8A4-IDG30	S6-198A4I*	19.0V	8.4A	100-240VAC	50-60Hz
S-24V0-6A6-IDG30	S6-246A6I	24.0V	6.6A	100-240VAC	50-60Hz
S-48V0-3A3-IDG30	S6-483A3I*	48.0V	3.3A	100-240VAC	50-60Hz

*Build to order items. Similar parts may be available in stock. Call for more details.

Input

- Voltage: 100~240VAC, C14 Socket Standard (C6 Optional)
- Line Frequency: 50~60Hz
- Current: 1.2A Max

Output

- Load Regulation: $\pm 5\%$ (Typical)
- Ripple: 1~2% Vp-p Max. for Output Voltage @ Full Load
- DC Cord: 16AWG
- Ferrite Cord: No
- DC Plug Options: Standard and Custom available

Environmental

- Operating/Storage Temperature: 0°C ~+40°C/ -20°C~+80°C
- Operating/Storage Humidity: 20%~80%RH/ 10%~90%RH



C6 Optional

Electrical

- Topology: LLC
- Dielectric Withstand: 3000VAC Primary – Secondary
- Leakage Current: 0.25mA
- MTBF: 300,000 Calculated Hours at 25°C
- Efficiency: DoE Level VI, Energy Star, ErP Stage 2, NRCan Certified
- EMI Conduction & Radiation: Compliance to EN 55022 Class B
- Harmonic Current Compliance to EN 61000-3-2,3
- EMS Immunity: Compliance to IEC 61000-4-2,3,4,5,6,8,11

Full Safety Standard Below

* **QUESTIONS ABOUT ANY OF CONDOR'S PRODUCTS PLEASE CALL/EMAIL 408-745-7141 / SALES@CONDORELECTRONICS.NET**

Safety Standards

Type(Marking)	Country/Region	Standard
UL/CUL	USA/Canada	Safety: UL 60950-1
		Safety: CSA C22.2 No 60950-1-07
FCC	USA	EMI: FCC Part 15, Subpart B, Class B
CE	Europe	In accordance with the council directive 2004/108/EC Adapter Standard: EN61204-3 EMI: EN 55022 EMS: EN 5502-4 ERP 5278/2009
CCC	China	Safety: GB-4946-2001
	China ROHS	EMI: GB9254-2008 EMS: GB17625.1-2003
PSE	Japan	適用試験基準：電気用品の技術上の基準を定める省令の解釈 Applied Standard for Testing: Description of the technical requirements by the METI Ordinance. 別表第十二 60950-1(h26), J55022(H22)
GS	Germany	Safety: EN 60950-1
BSMI	Taiwan	Safety: CNS14336-1 (99) 年版 EMI: CNS13438 (95) 年版

